

NOTES:
 1. ALL DIMENSIONS +/- 1.0MM UNLESS NOTED
 2. DIMENSIONS SHOWN ARE FOR ALL TOUCH TECHNOLOGIES UNLESS NOTED.

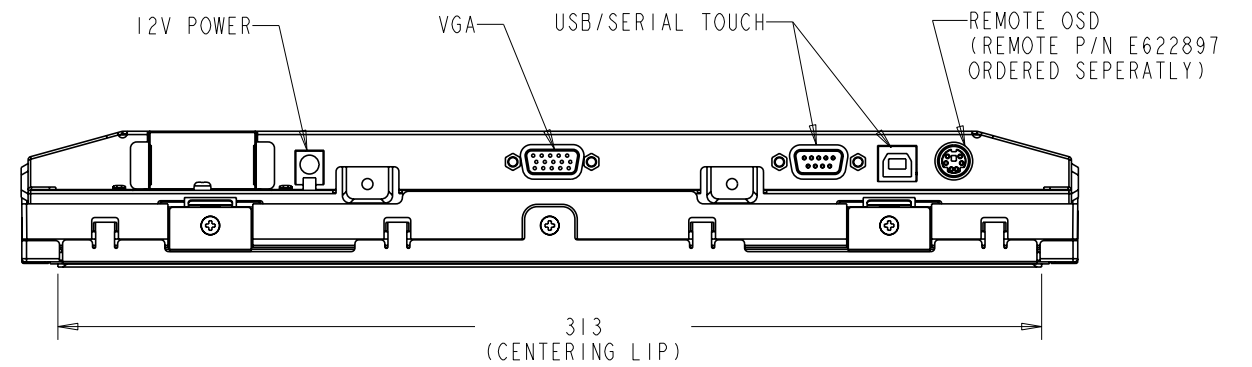

IR OPTION

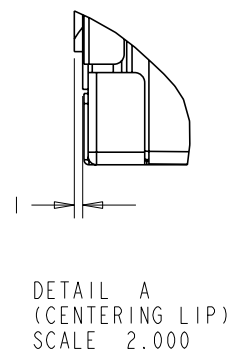
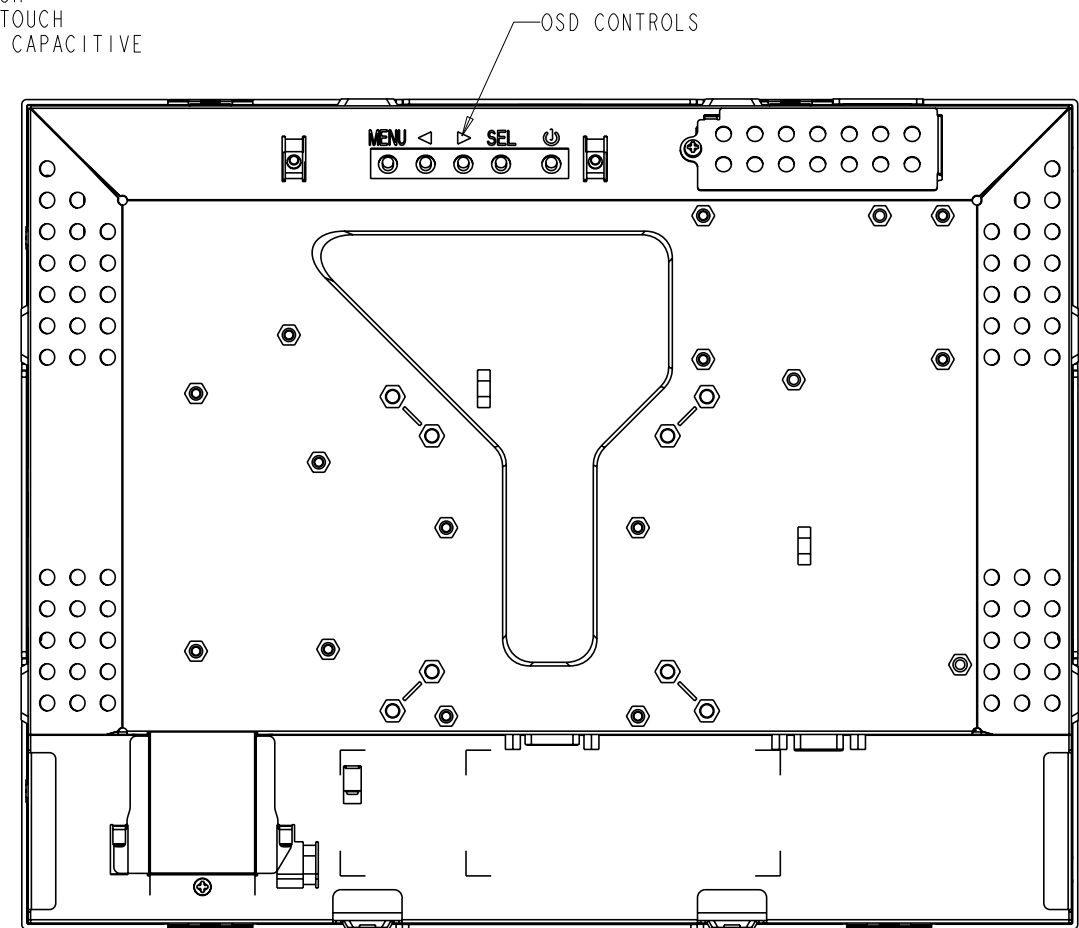
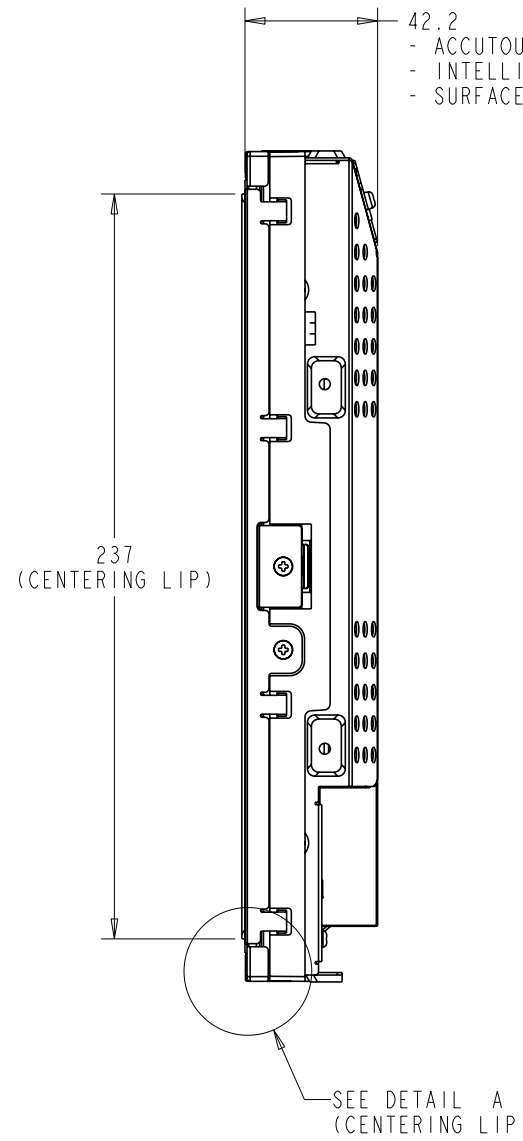
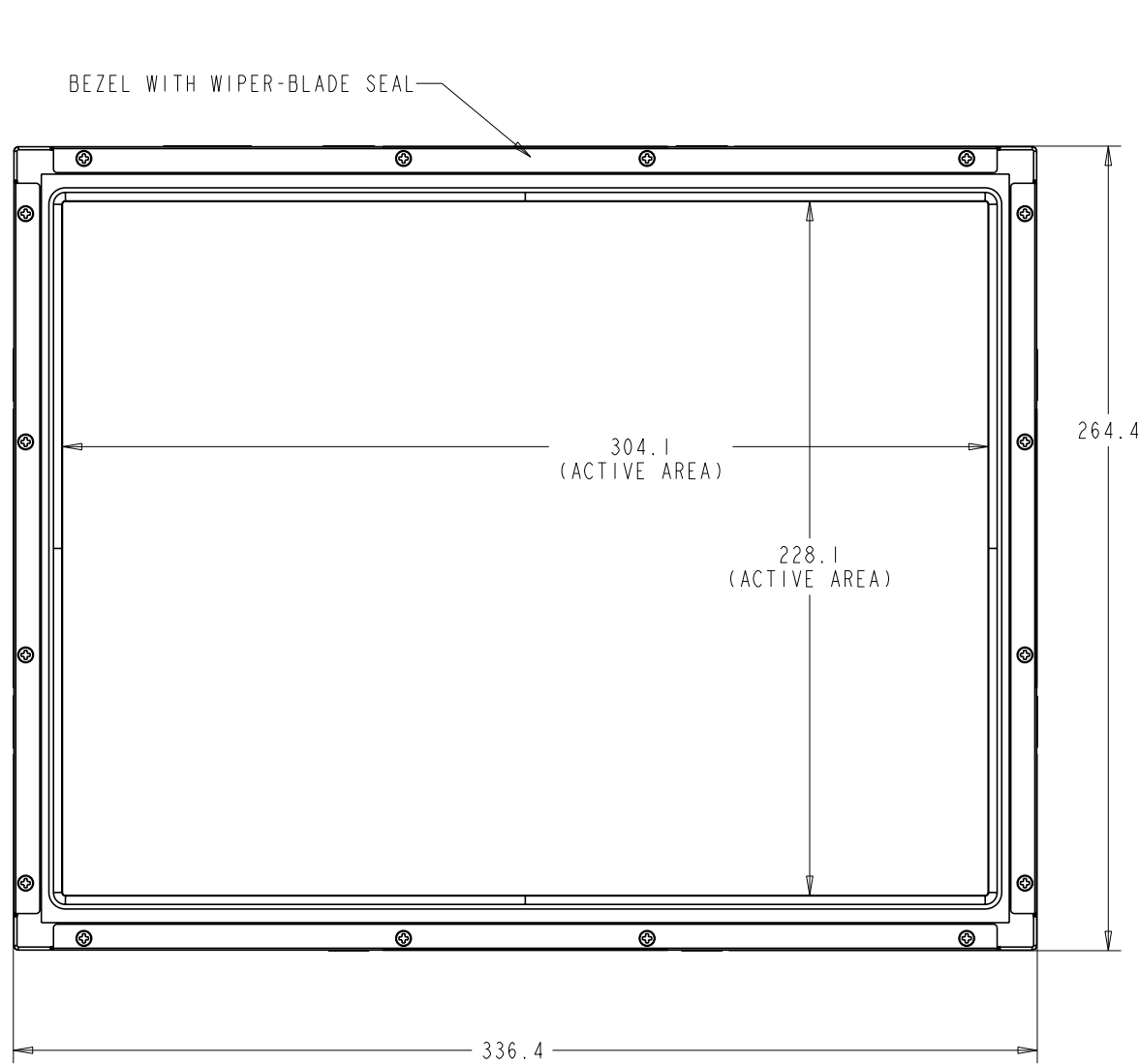
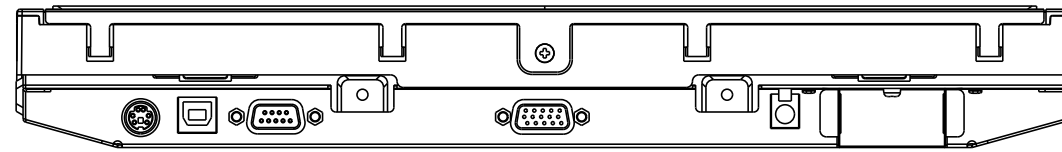
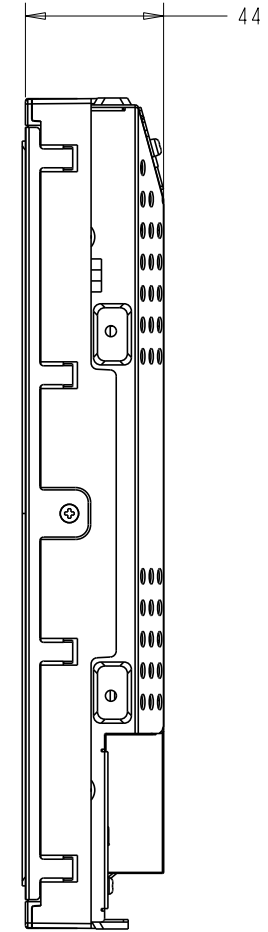
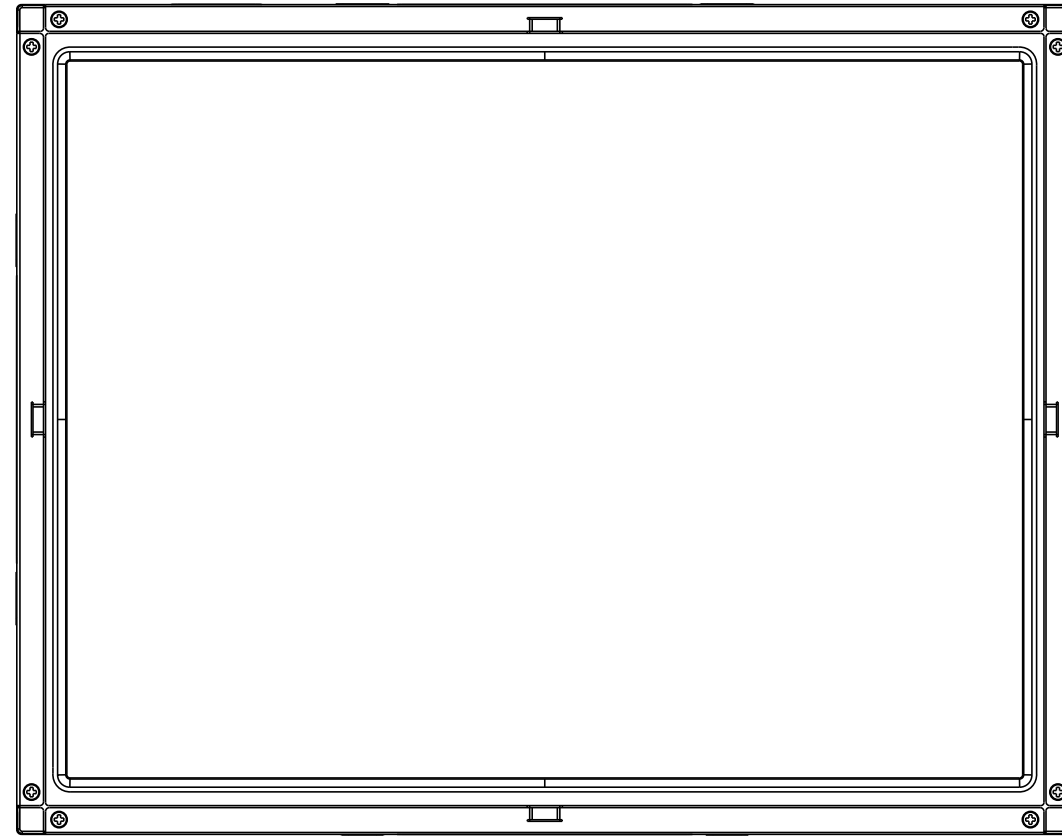

SECURETOUCH OPTION

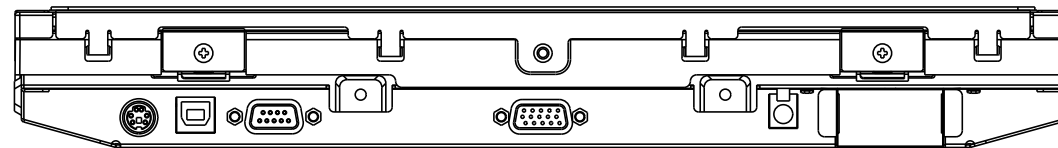
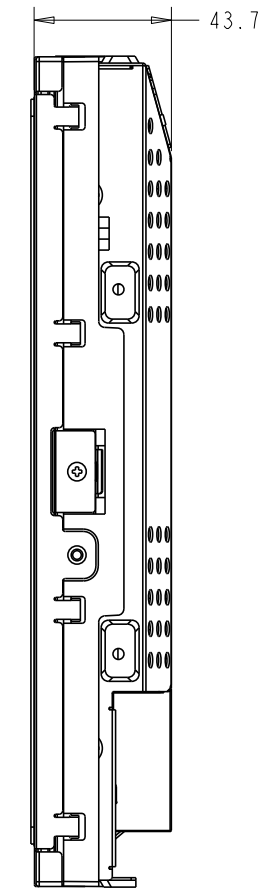
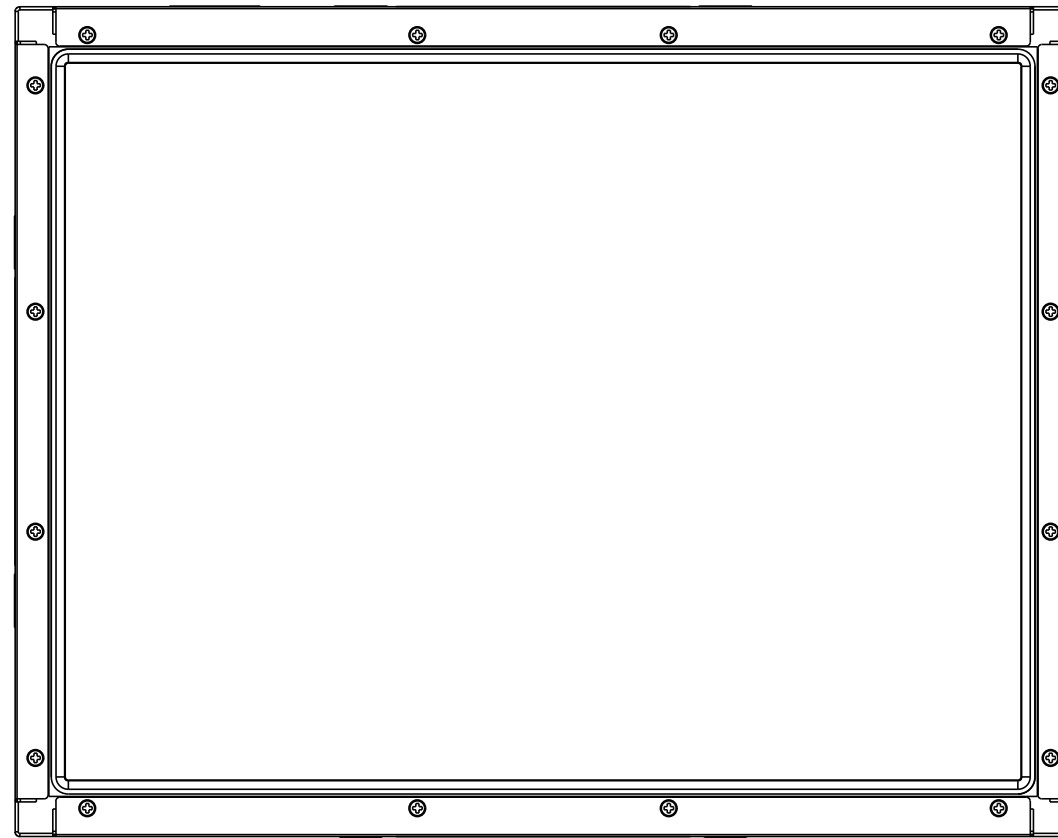

APR OPTION

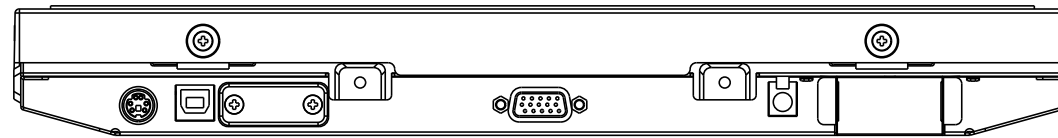
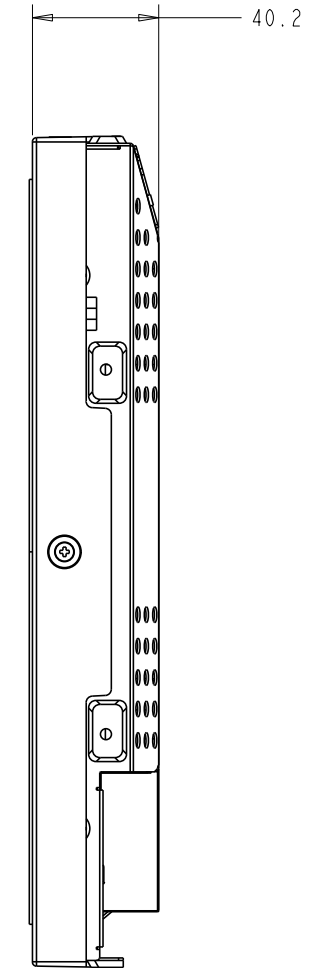
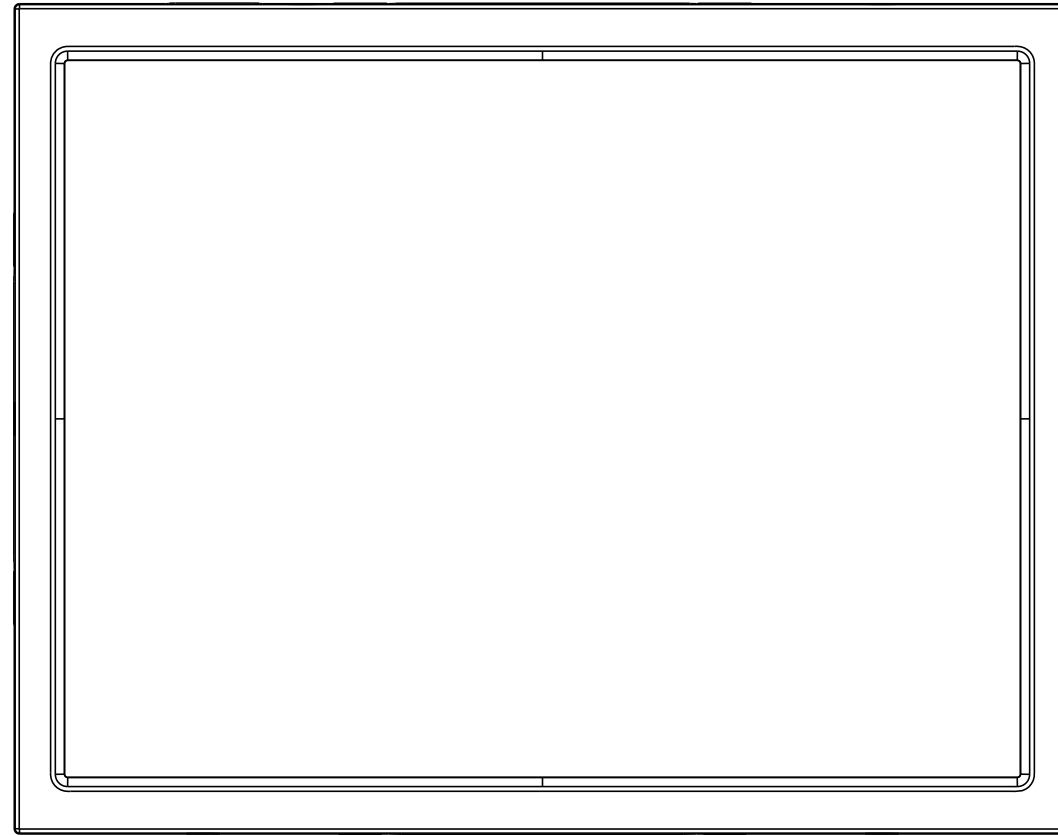

**RECOMMENDED CUSTOMER
PANEL CUT-OUT** (SEE NOTE A)

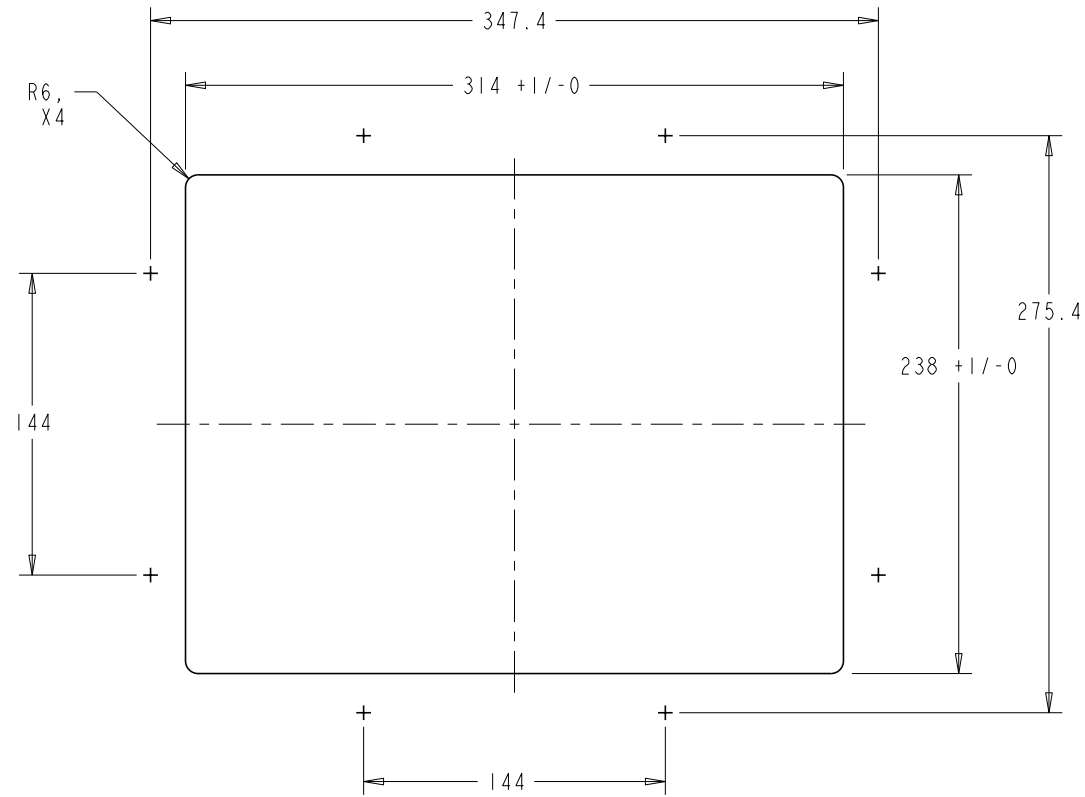

NOTE A
CUSTOMER PANEL MATERIAL:

1. WOOD: $\varnothing 4.5$ HOLES THRU FOR M4 SCREWS W/NUTS, OR, NO THRU HOLES, SCREWS FOR WOOD $\varnothing 4$ mm,

2. SHEET METAL: CONCEALED HEAD THREADED STUDS M4 W/NUTS.

NOTE B

MONITOR INCLUDES 2 BRACKETS, ADDITIONAL BRACKETS AVAILABLE, P/N E203787

NOTE C

27.2 mm = SECURE TOUCH AND IR

VESA MOUNT

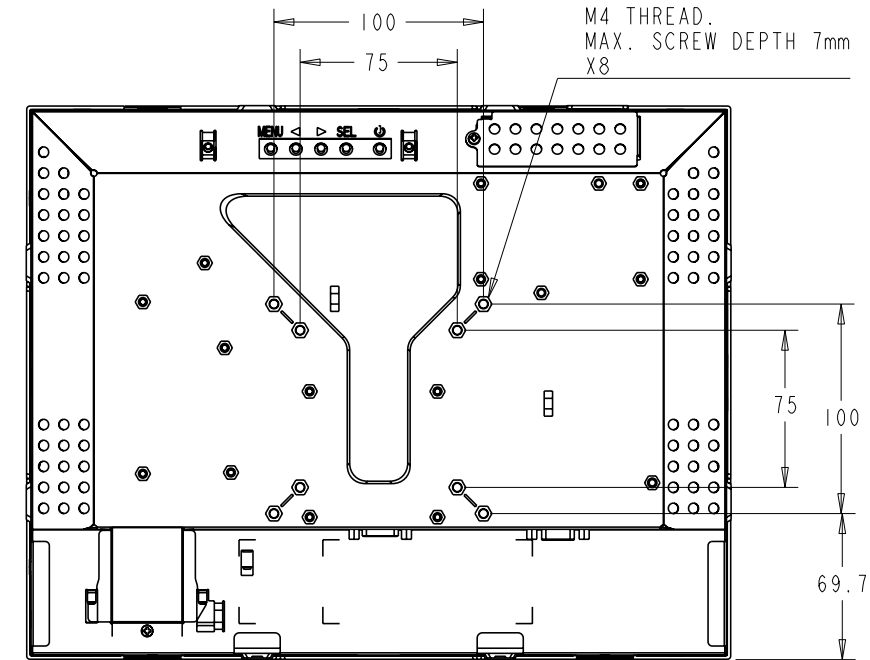

SIDE MOUNT, VERTICAL

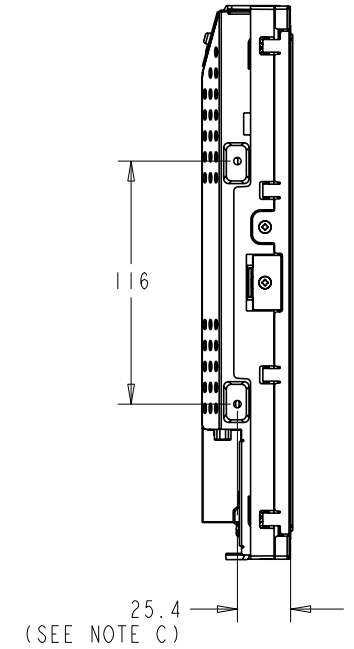

**REAR MOUNT WITH BRACKETS,
HORIZONTAL AND VERTICAL** (SEE NOTE B)

MOUNTING BRACKETS ACCOMMODATE MAX. 14mm MATERIAL THICKNESS.

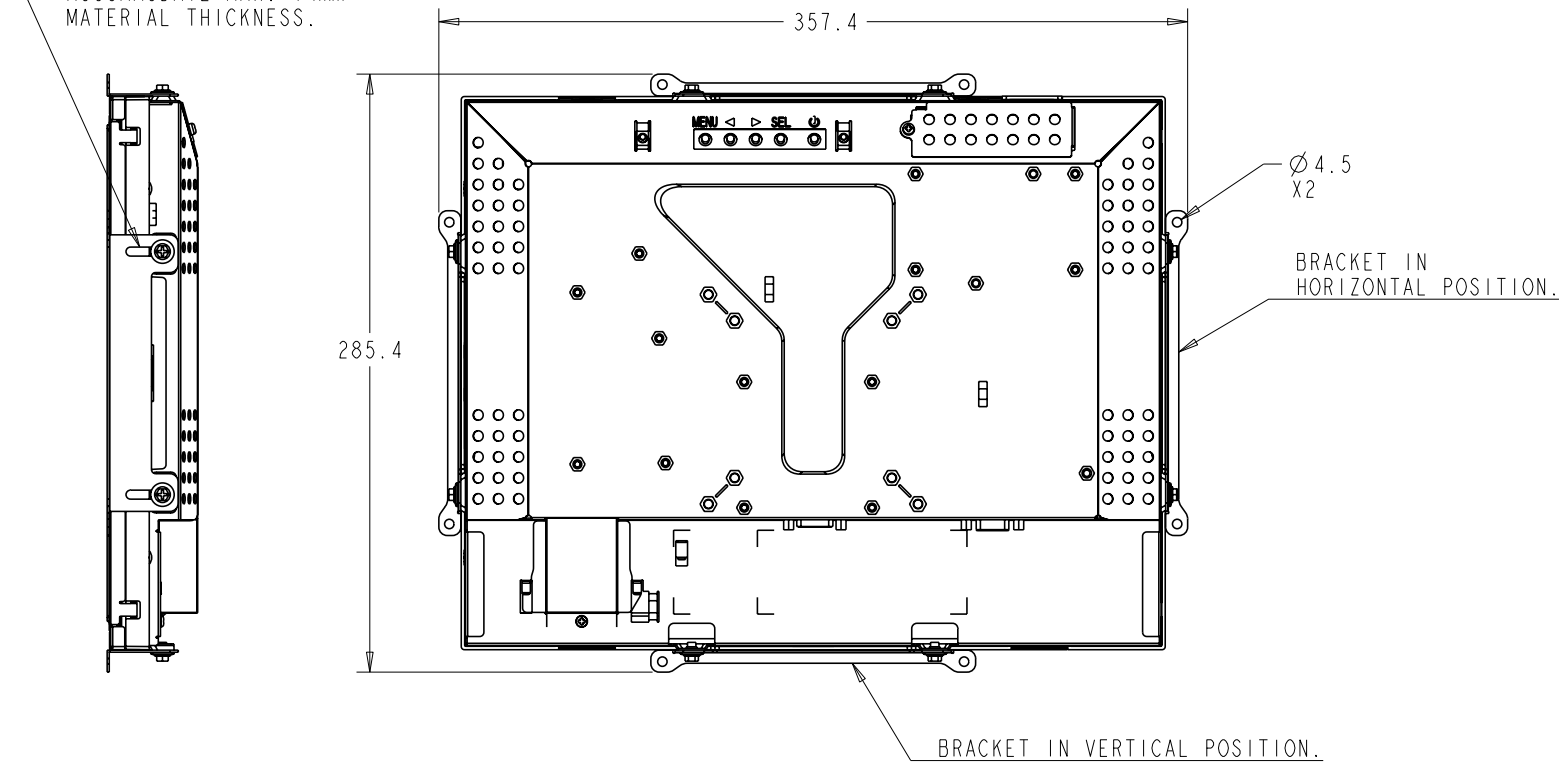

SIDE MOUNT, HORIZONTAL

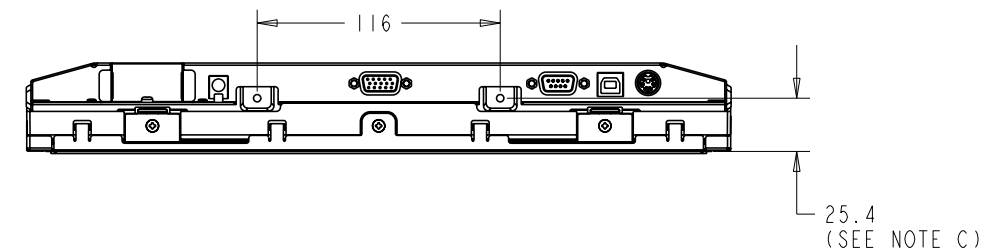

FRONT MOUNT OPTION

P/N E323425

(ORDERED SEPERATLY, CUSTOMER ASSEMBLED)

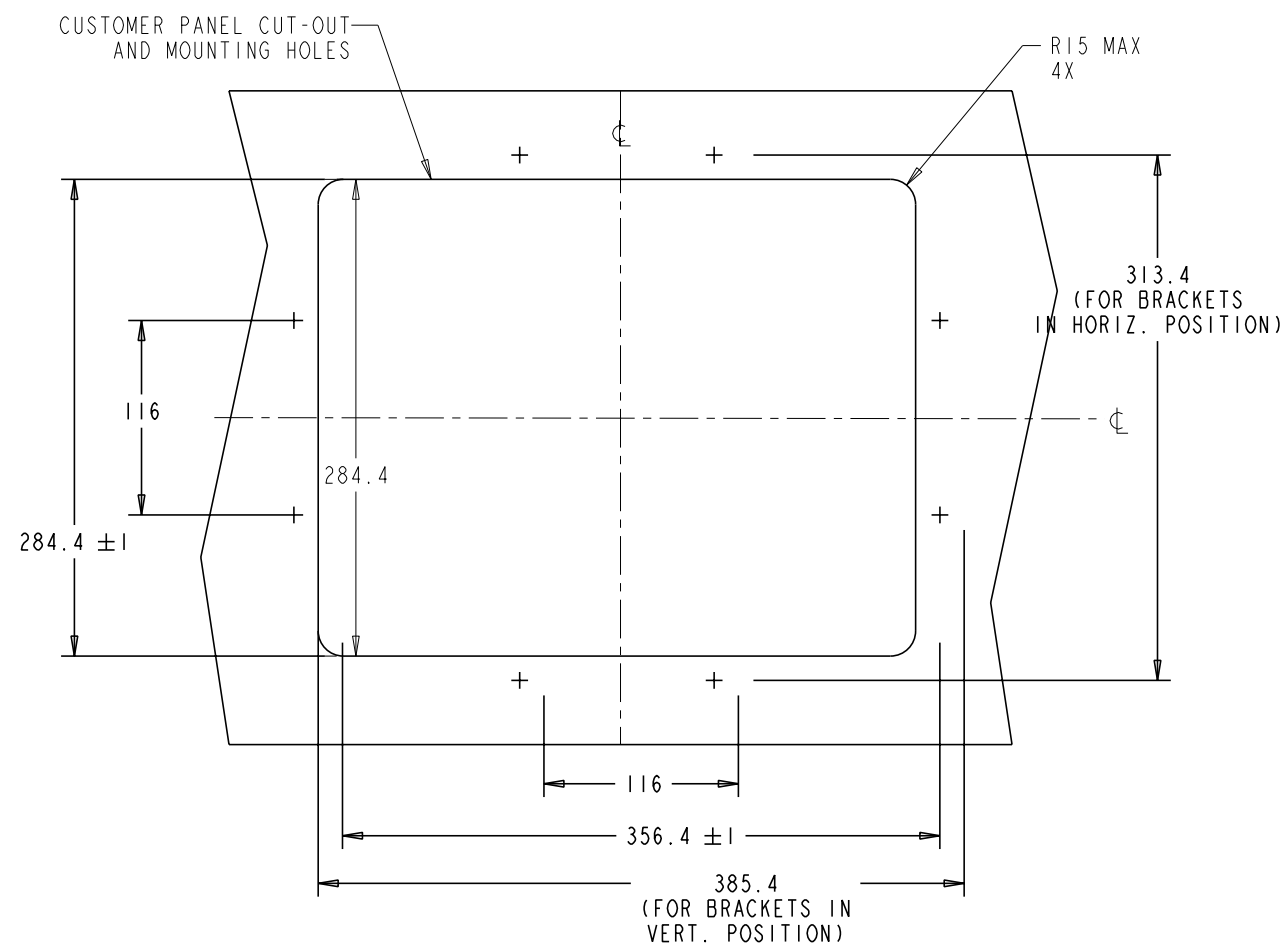
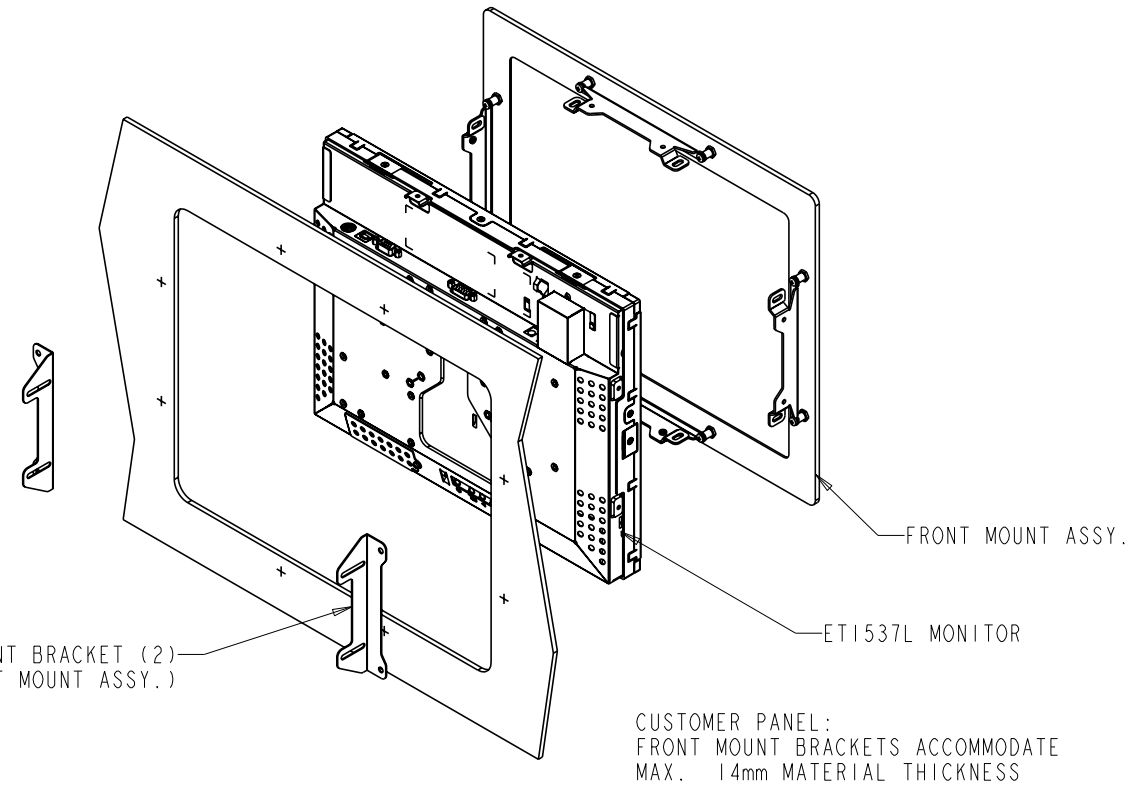
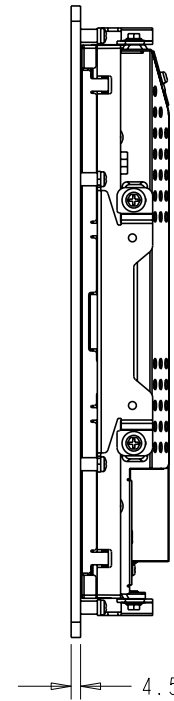
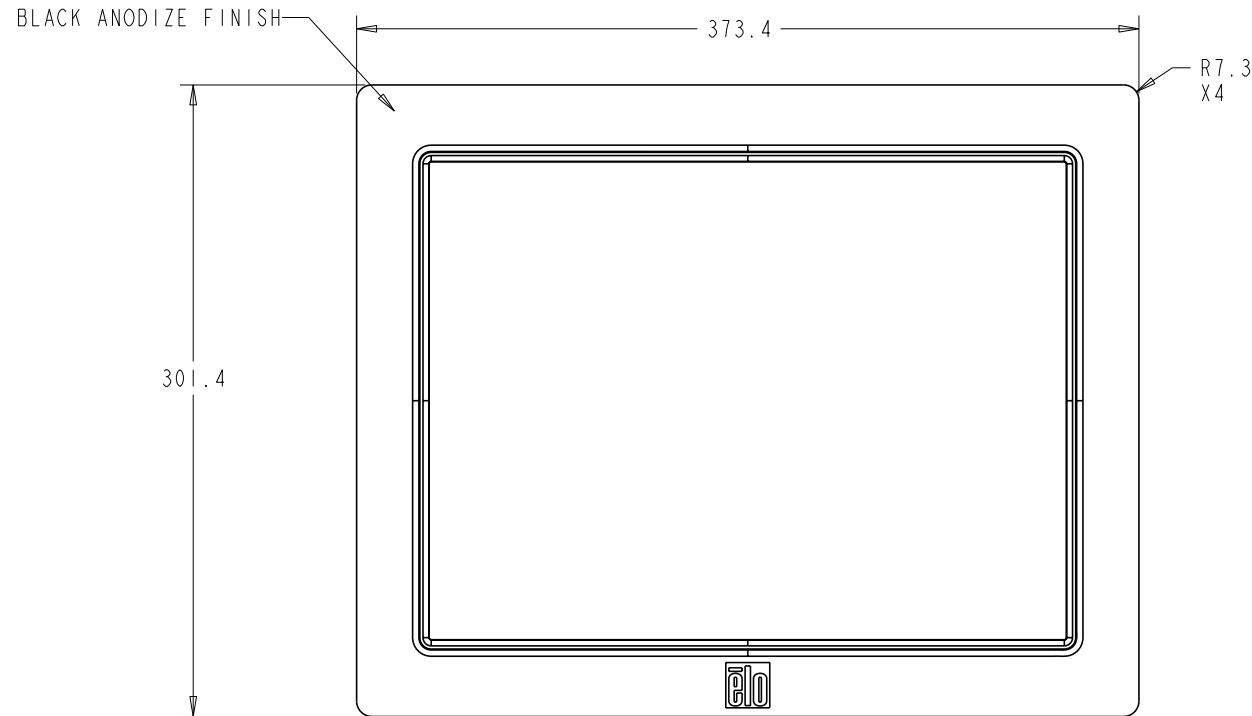

- NOTE:
1. IF CUSTOMER PANEL MATERIAL IS WOOD:
Ø 4.5mm HOLES THRU FOR M4 SCREWS,
OR NO THRU HOLES, SCREWS FOR WOOD Ø 4mm.
 2. IF CUSTOMER PANEL MATERIAL IS SHEET METAL:
CONCEALED HEAD THREADED STUDS M4 WITH NUTS.

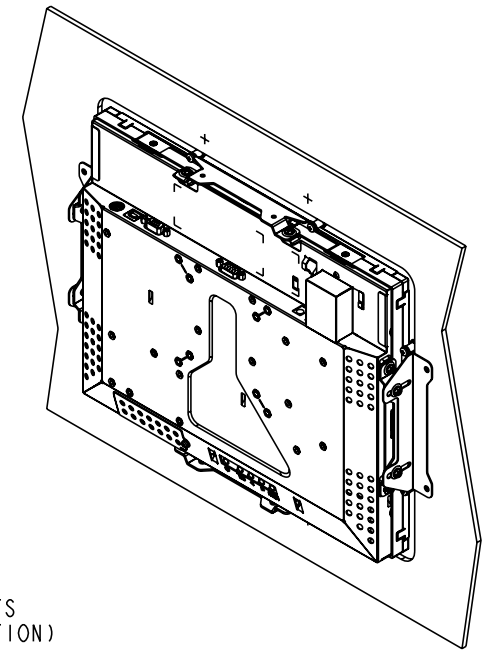
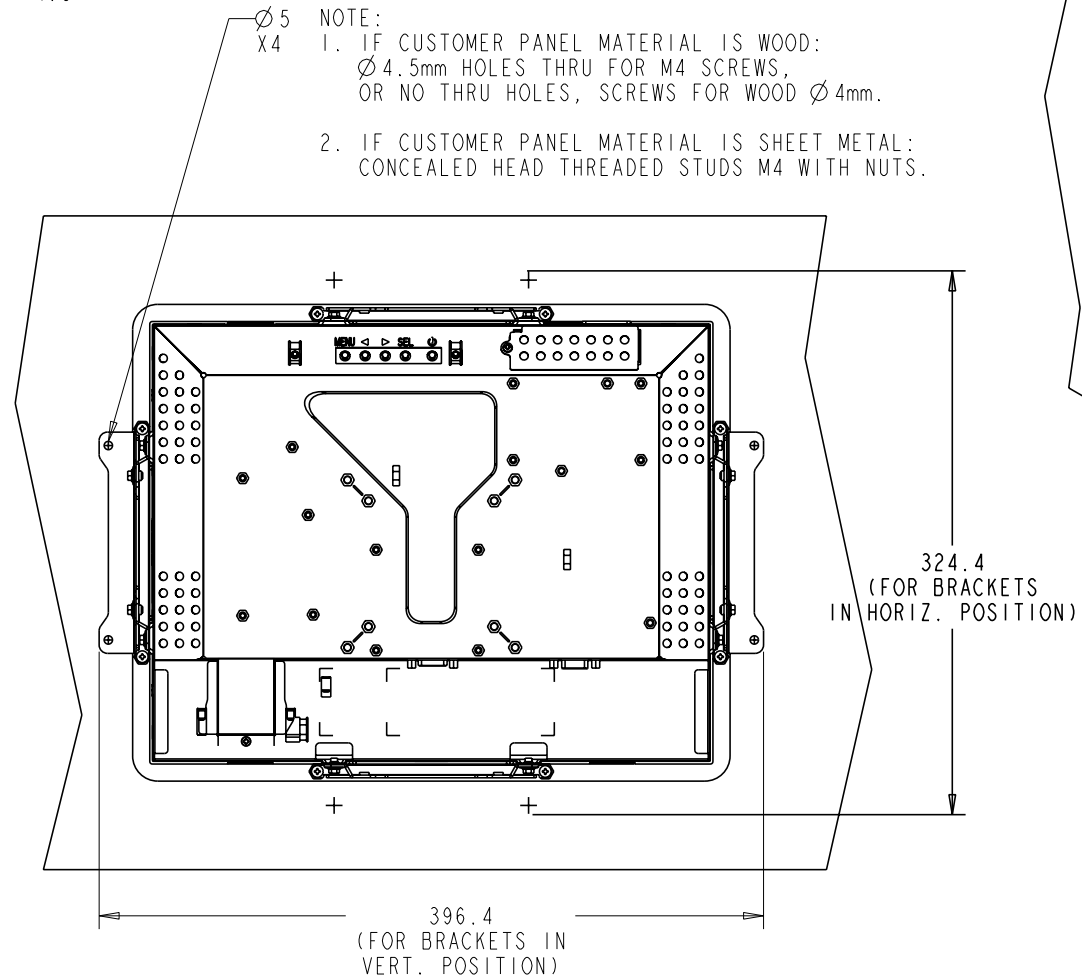

RACK MOUNT OPTION

P/N E295006

(ORDERED SEPERATLY, CUSTOMER ASSEMBLED)

